

Timed Dosing Control SJE-Rhombus® Type TD

Installation Instructions and Operation/Troubleshooting Manual

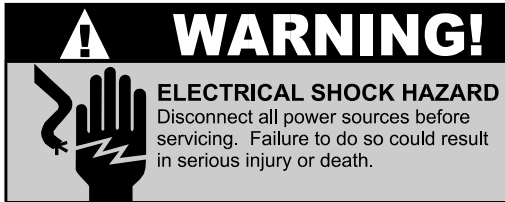

This control panel must be installed and serviced by a licensed electrician in accordance with the National Electric Code NFPA-70, state and local electrical codes.

All conduit running from the sump or tank to the control panel must be sealed with conduit sealant to prevent moisture or gases from entering the panel. **NEMA 4X enclosures are for indoor or outdoor use**, primarily to provide a degree of protection against corrosion, windblown dust and rain, splashing water and hose-directed water. **Cable connectors must be liquid-tight in NEMA 4X enclosures.**

Installation

Type TD control panels are designed to operate with two, three or four float systems. The two float system utilizes one float as the “low level cutout”, the second as “high level alarm”. A three float system adds either a “redundant off” float or a “timer override” float to the “low level cutout” and “high level alarm” functions. A four float system includes a “redundant off float”, a “low level cutout” float, a “timer override” float, and a “high level alarm” float.

NOTE: Options ordered may affect the number of floats and their functions. Please reference the schematic provided with the control panel.

Warranty void if panel is modified.

Call factory with servicing questions:
1-800-RHOMBUS
(1-800-746-6287)

Installation of Floats

CAUTION: If control switch cables are not wired and mounted in the correct order, the pump system will not function properly.

WARNING: Turn off all power before installing floats in pump chamber. Failure to do so could result in serious or fatal electrical shock.

1. Use float label kit to identify and label cables on both the float and stripped ends (low level cutout, alarm, etc.). See schematic for float options.
2. Determine your normal operating level and desired float configuration, as illustrated in **Figures 1-4**.
3. Mount float switches at appropriate levels as illustrated in **Figures 1-4**. Be sure that floats have free range of motion without touching each other or other equipment in the basin.
4. For mounting clamp installation: place the cord into the clamp as shown in **Figure 5**. Locate the clamp at the desired activation level and secure the clamp to the discharge pipe as shown in **Figure 5**.

NOTE: Do not install cord under hose clamp.

5. Tighten the hose clamp using a screwdriver. Over tightening may result in damage to the plastic clamp. Make sure the float cable is not allowed to touch the excess hose clamp band during operation.

NOTE: All hose clamp components are made of 18-8 stainless steel material. See your SJE-Rhombus® supplier for replacements.

6. If using an optional redundant off float, mount slightly below the low level cutout float, but above the pump as illustrated in **Figures 2 & 4**.
7. If using an optional timer override float, position it at a level in the basin as shown in **Figure 3 & 4**.

Manufactured by:

SJE
Rhombus
CONTROLS

22650 County Highway 6 ■ P.O. Box 1708
Detroit Lakes, Minnesota 56502 USA
1-888-DIAL-SJE (1-888-342-5753)
Phone: 218-847-1317 ■ Fax: 218-847-4617
E-mail: sje@sjerhombus.com
Website: www.sjerhombus.com

Installation Instructions

Mounting the Control Panel

1. Determine mounting location for panel. If distance exceeds the length of either the float switch cables or the pump power cables, splicing will be required. For outdoor or wet installation, we recommend the use of an SJE-Rhombus® liquid-tight junction box with liquid-tight connectors to make required connections. **You must use conduit sealant to prevent moisture or gases from entering the panel.**
2. Mount control panel with mounting devices furnished.
3. Determine conduit entrance locations on control panel. Check local codes and schematic for the number of power circuits required.

NOTE: Be sure the proper power supply voltage, amperage, and phase meet the requirements of the pump motor being installed. If in doubt, see the pump identification plate for voltage/phase requirements.

4. Drill proper size holes for type of connectors being used.

NOTE: If using conduit, be sure that it is of adequate size to pull the pump and switch cables through.

5. Attach cable connectors and/or conduit connectors to control panel.

6. Determine location for mounting junction box according to local code requirements. **Do not** mount the junction box inside the sump or basin.
7. Mount junction box to proper support.
8. Run conduit to junction box. Drill proper size holes for the type of conduit used.
9. Identify and label each wire before pulling through conduit into control panel and junction box. Make wire splice connections at junction box.
10. Firmly tighten all fittings on junction box.
11. If a junction box is not required, pull cables through conduit into control panel.
12. Connect pump wires and float switch cables to the proper terminals as seen in **Figures 6 & 7**. If the redundant off float is not required, place a jumper wire across TB1-7 and TB1-8.
13. Connect pump/control and alarm incoming power conductors to proper position on terminals. See schematic and wiring diagram for terminal connections.

VERIFY CORRECT OPERATION OF CONTROL PANEL AFTER INSTALLATION IS COMPLETE.

FOR INSTALLATION REQUIRING A SPLICE, FOLLOW STEPS 6-10; FOR INSTALLATION WITHOUT A SPLICE, GO TO STEP 11.

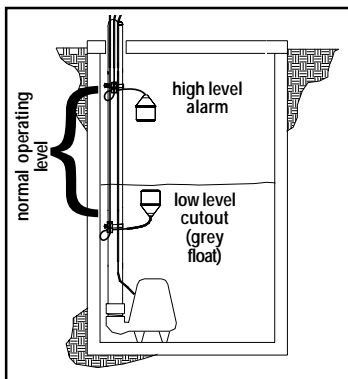

**FIGURE 1 -
Two float system**

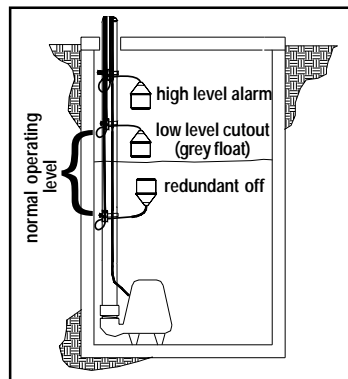

**FIGURE 2 -
Three float system
with redundant off**

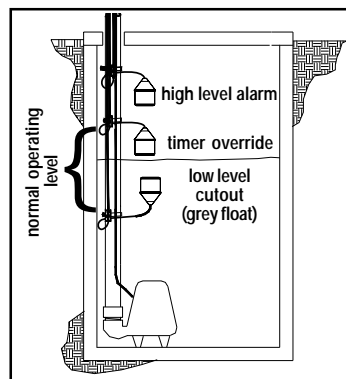

**FIGURE 3 -
Three float system
with timer override**

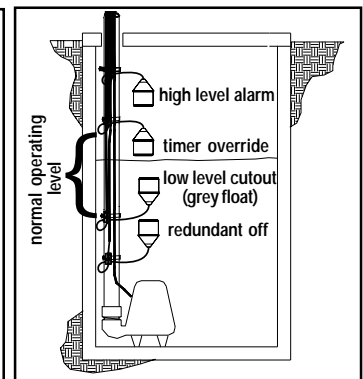

**FIGURE 4 -
Four float system**

Installation Instructions

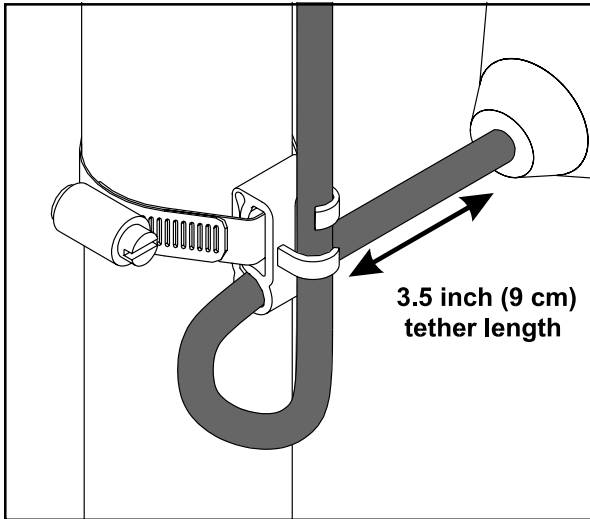

FIGURE 5 - Mounting clamp detail.

Option 4E Redundant Off / Alarm Activation Wiring Diagram

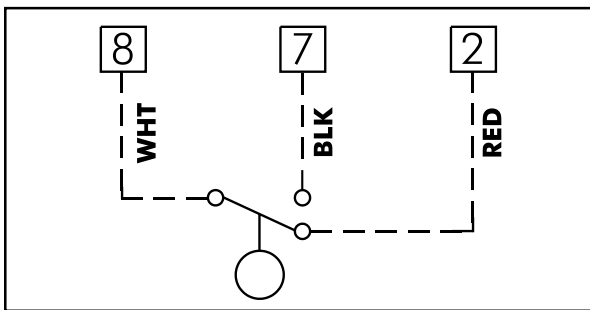

FIGURE 7 -
Redundant off pump

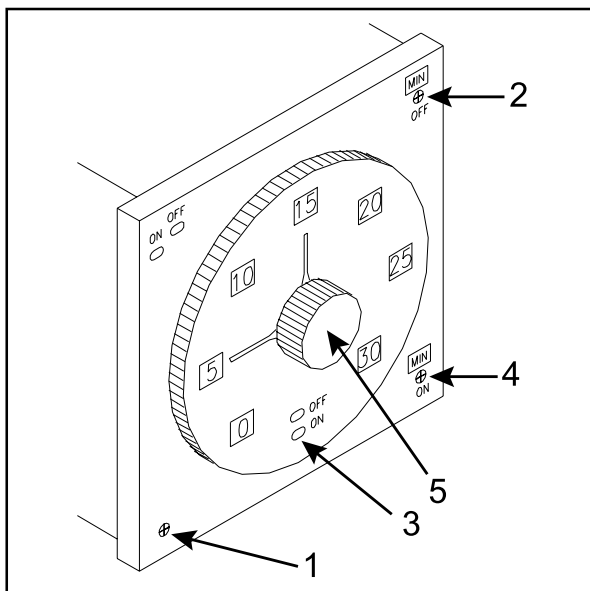

FIGURE 8 - Timer detail

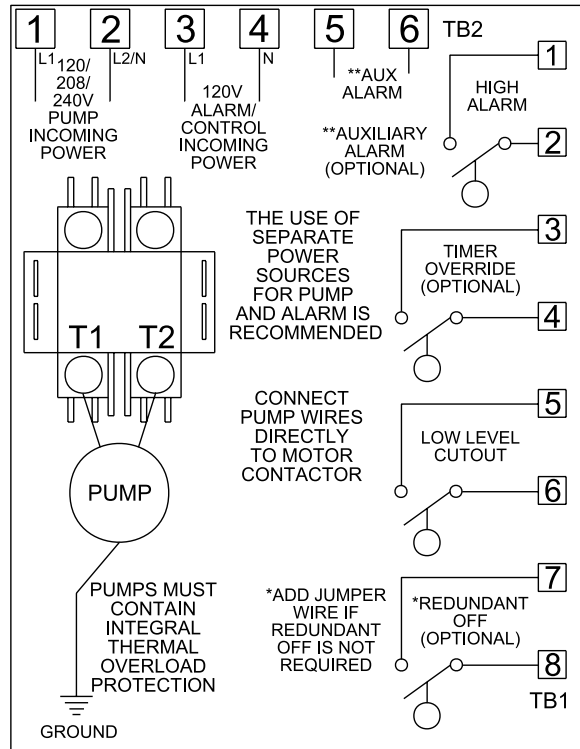

FIGURE 6 -
TD wiring diagram

Setting the timer

Remove the timer by clipping the tie strap and pulling it straight out of the socket.

1. Determine the pump "on & off" time and turn the adjustment screw (1) so that the most appropriate range of numbers (usable for both the on and off cycles) is visible in the windows on the dial face.
2. Adjust the off time range selector (2) to the appropriate period. (e.g.: minutes).
3. Adjust the outer dial (3) so the green pointer indicates the off time period required. (e.g.:15)
4. Adjust the on timer range selector (4) to the appropriate period (e.g.: minutes).
5. Adjust the inner dial (5) so the red pointer indicates the on time period required. (e.g.: 5)
6. When setting is complete, place the timer back in the socket.
7. In the example shown, the pump would be off for 15 minutes and then on for 5 minutes. This cycle would continue as long as there was enough liquid in the tank to float the low level cutoff switch.

NOTE: "OFF" time is cycled first.

Operations & Troubleshooting

TD series control panels are available for use with two, three or four float combinations. In a two float system, one float in the tank is the “low level cutout” float

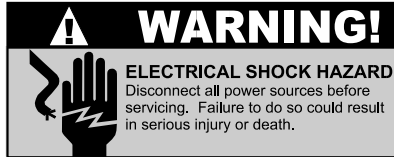

while the other is a “high level alarm” float. The normal operating level should be between the “low level cutout” position and the “high level alarm” position.

The TD panel can be installed with a choice of three float systems. One choice adds a “redundant off” float which is positioned slightly below the “low level cutout” grey float, but above the pump. The normal operating level shall be between the “low level cutout” position and the “high level alarm” position. The other choice adds a “timer override” float which is positioned between the “low level cutout” (grey float) and the “high level alarm” float. Normal operating level should be between the “low level cutout” float and the “timer override” float.

A four float system includes a “redundant off” float, a “low level cutout” float, a “timer override” float and a “high level alarm” float. The “timer override” float gives you the option of pumping from the basin while the timer is in the “off” cycle. It is only intended for times of abnormally high liquid level inrushes. The normal operating level should be between the “low level cutout” float and the “timer override” float.

The control panel begins timing the “off” sequence when the “low level cutout” float is activated. Once the timer completes the “off” sequence, the timer will start the pump and continue to run until the programmed “on” sequence is complete. At this point the “off” sequence begins timing again and the cycle repeats.

Float Controls

1. Check the floats during their entire range of operation. Clean, adjust, replace and repair damaged floats.
2. Measure the float resistance to determine if the float is operating properly.

To measure float resistance:

- a. Isolate the float by disconnecting one or both of the float leads from the float terminals.
- b. Place one ohmmeter lead on one of the float wires, and the other ohmmeter lead on the other float wire.
- c. Set the ohmmeter dial to read ohms and place on the R X 1 scale. With the float in the “off” position, the scale should read infinity (high resistance), if not replace the float.

With the float in the “on” position, the scale should read close to zero, if not replace the float. **Readings may vary depending on the accuracy of the measuring device.**

Magnetic Contactor Coil

To measure the coil, disconnect one of the coil leads. Measure the coil resistance by setting the ohmmeter on the R X 1 scale. A defective coil will read zero indicating a short, or infinity (high resistance) indicating an opened coil. Replace defective contactor.

Fuses

To check the continuity of the fuse, pull the fuse out of the fuse holder. With the ohmmeter on the R X 1 scale, measure resistance. A reading of infinity (high resistance) indicates a blown fuse that must be replaced with a fuse of the same type, voltage, and amp rating.

Alarm Light

Activate the alarm float. The alarm light should turn on. If not, replace the bulb with that of the same type.

Alarm Horn

Activate the alarm float. The alarm horn should turn on. If not, replace the horn with that of the same type.

SJE-Rhombus® Three-Year Limited Warranty

SJE-RHOMBUS® warrants to the original consumer that this product shall be free of manufacturing defects for three years after the date of consumer purchase. During that time period and subject to the conditions set forth below, **SJE-RHOMBUS®** will repair or replace, for the original consumer, any component which proves to be defective due to defective materials or workmanship of **SJE-RHOMBUS®**.

ELECTRICAL WIRING AND SERVICING OF THIS PRODUCT MUST BE PERFORMED BY A LICENSED ELECTRICIAN.

THIS WARRANTY DOES NOT APPLY: (A) to damage due to lightning or conditions beyond the control of **SJE-RHOMBUS®**; (B) to defects or malfunctions resulting from failure to properly install, operate or maintain the unit in accordance with printed instructions provided; (C) to failures resulting from abuse, misuse, accident, or negligence; (D) to units which are not installed in accordance with applicable local codes, ordinances, or accepted trade practices, and (E) to units repaired and/or modified without prior authorization from **SJE-RHOMBUS®**.

Some states do not allow limitations on how long an implied warranty lasts, so the above limitation may not apply to you. Some states do not allow the exclusion or limitation of incidental or consequential damages, so the above limitation or exclusion may not apply to you. This warranty gives you specific legal rights, and you may also have other rights which vary from state to state.

TO OBTAIN WARRANTY SERVICE: The consumer shall assume all responsibility and expense for removal, reinstallation, and freight. Any item to be repaired or replaced under this warranty must be returned to **SJE-RHOMBUS®**, or such place as designated by **SJE-RHOMBUS®**.

ANY IMPLIED WARRANTIES OF MERCHANTABILITY OR FITNESS ARE LIMITED TO THE DURATION OF THIS WRITTEN WARRANTY. SJE-RHOMBUS® SHALL NOT, IN ANY MANNER, BE LIABLE FOR ANY INCIDENTAL OR CONSEQUENTIAL DAMAGES AS A RESULT OF A BREACH OF THIS WRITTEN WARRANTY OR ANY IMPLIED WARRANTY.